

Data sheet

Actuators for modulating control

AME 55, AME 56

Description

**Features:**

- "Self adjustment" function
- Load related "Switch off" function that prevents valve or actuator to be overloaded
- Diagnostic LED

Main data:

- Nominal voltage: 24 Vac, 50/60 Hz
- Control input signal:
0(4)-20 mA,
0(2)-10 Vdc
- Force:
2000 N (AME 55),
1500 N (AME 56)
- Stroke: 40 mm
- Speed:
8 s/mm (AME 55),
4 s/mm (AME 56)
- Max. medium temperature: 200 °C by insulated valve
- Manual operation

The actuators are used with valves:

- VFM 2 (DN 65-150) only in combination with AME 55,
- VFS 2 (DN 15-50) only in combination with AME 56. Clutch available on special request,
- VFS 2 (DN 65-100),
- VL 2/3 (DN 100),
- VF 2/3 (DN 100-150),
- VL 2/3 & VF 2/3 (DN 65, 80) only in combination with AME 56 and adapter **065Z0312**,
- AFQM (DN 65-125) and AFQM 6 (DN 40-50)

Ordering

Actuators

Type	Power supply	Code No.
AME 55	24 Vac	082H3022
AME 56		082H3025

Accessories

Type	Code No.
Stem heater 24 Vac/dc; 40W (VF, VL valves DN 65-80)	065Z0315
Stem heater 24 Vac/dc; 20W (VF, VL valves DN 100 and VFS2 valves DN 15-50)	065Z7020
Stem heater 24 Vac/dc; 40W (VF valves DN 125, 150 and VFS DN 65-100)	065Z7022
Adapter (VF, VL valves DN 65-80)	065Z0312
AME 56 clutch (VFS 2 DN 15-50)	065Z7551

Technical data

Type		AME 55	AME 56
Power supply	Vac	24; ± 10 %	
Power consumption	VA	9	19.5
Duty cycle		S3 60% ED (IEC 60034)	
Frequency	Hz	50/60	
Control input Y	Vdc	0-10 (2-10) Ri = 24 kΩ	
	mA	0-20 (4-20) Ri = 500 Ω	
Output signal X	Vdc	0-10 (2-10)	
Closing force	N	2000	1500
Max. stroke	mm	40	
Speed	s/mm	8	4
Max. medium temperature		200	
Ambient temperature	°C	0 ... 55	
Storage and transport temperature		-40 ... 70	
Ambient humidity		95 % r.h., non-condensing	
Protection class		III	
Grade of enclosure		IP 54	
Weight	kg	3.8	
- marking in accordance with standards		Low Voltage Directive (LVD) 2014/35/EU: EN 60730-1, EN 60730-2-14 Electromagnetic Compatibility Directive (EMC) 2014/30/EU: EN 61000-6-2, EN 61000-6-3	

Installation

Mechanical

The actuator should be mounted with the valve stem (use a 4 mm Allen key - not supplied) in either horizontal position or pointing upwards. Use a M8/SW13 key (not supplied) to fit the actuator to the valve body. Allow for necessary clearance for maintenance purposes.

Red rings position indication should be pushed together before commissioning. They indicate the position of valve opening degree after self-adjustment.

Arrange proper valve insulation in order to avoid direct heat transfer toward actuator.

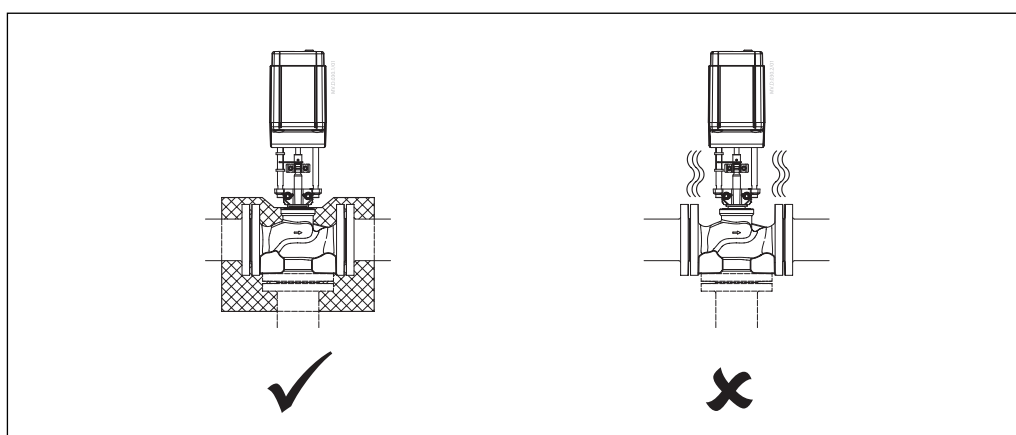
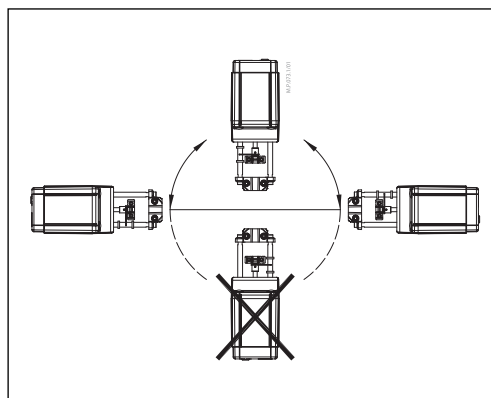

Electrical

Electrical connections can be accessed by removing the cover.

Two M16 × 1.5 cable entries are provided. Both entries are provided with a rubber grommet for use with flexible cable. Note that in order to maintain the enclosure IP rating, appropriate cable glands must be used.

Wiring length	Recommended square of the wiring
0-50 m	0.75 mm ²
> 50 m	1.5 mm ²

Disposal

The actuator must be dismantled and the elements sorted into various material groups before disposal.

DIP switch setting

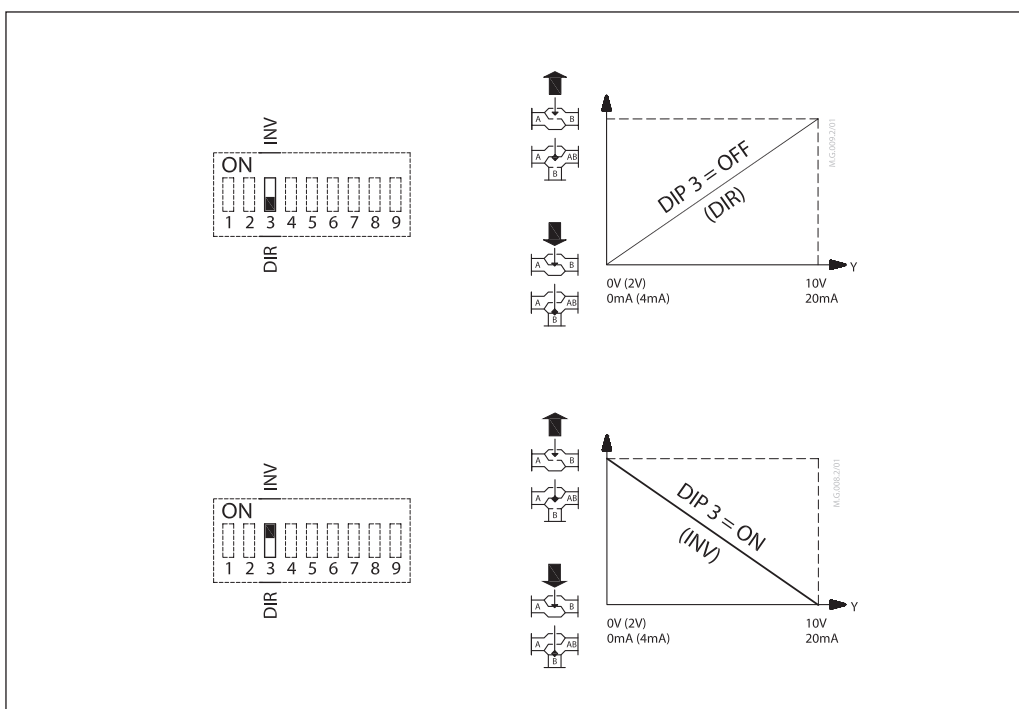
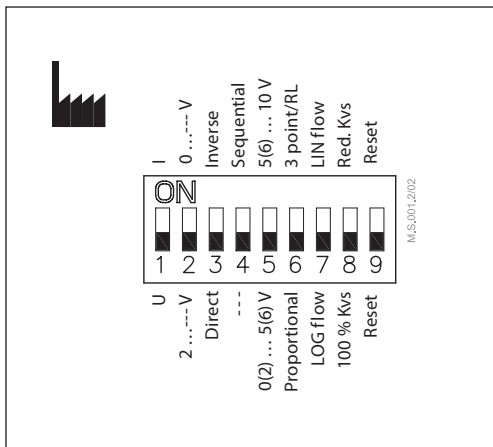

The actuator has a selection of DIP switches under the removable cover. The switch provides the following functions:

DIP1: U/I - Input signal type selector:

- If set to OFF position, input signal Y is set to voltage (V).
If set to ON position, input signal Y is set to be current (mA).

DIP2: 0/2 - Input signal range selector:

- If set to OFF position, the input signal is in the range from 2 V to 10 V (voltage input) or from 4 mA to 20 mA (current input). If set to ON position, the input signal is in the range from 0 V to 10 V (voltage input) or from 0 mA to 20 mA (current input).

DIP3: D/I - Direct or inverse acting selector:

- If set to OFF position, the actuator is direct acting (actuator's stem extends by voltage increase). If actuator is set to ON position the actuator is inverse acting (actuator's stem retracts by voltage increase).

DIP4: —/Seq - Normal or sequential mode selector:

- Two actuators can be set to work parallel with one control signal. If the SEQUENTIAL is set than an actuator responds to split control signal (see 0(2) V ... 5(6) V / 5(6) V ... 10 V).

NOTE: This combination works in combination with DIP5: 0(2) V ... 5(6) V / 5(6) V ... 10 V

DIP switch setting
(continuous)

DIP5: 0-5 V/5-10 V - Input signal range in sequential mode:

- This function is available if DIP4: --- / Sequential is set to ON, otherwise the actuator operates in full controll range (0(2)-10V or 0(4)-20mA).
- When **DIP5** is set to **Off** the actuator will match the range of the control signal:
 2 ... 6 V (when **DIP1** and **DIP2** are set to **Off**)
 0 ... 5 V (when **DIP1** is set to **Off** and **DIP2** is set to **ON**)
 4 ... 12 mA (when **DIP1** is set to **ON** and **DIP2** is set to **Off**)
 0 ... 10 mA (when **DIP1** & **DIP2** are set to **ON**)

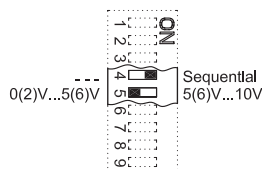

- When **DIP5** is set to **ON** the actuator will match the range of the control signal:
 6 ... 10 V (when **DIP1** and **DIP2** are set to **Off**)
 5 ... 10 V (when **DIP1** is set to **Off** and **DIP2** is set to **ON**)
 12 ... 20 mA (when **DIP1** is set to **ON** and **DIP2** is set to **Off**)
 10 ... 20 mA (when **DIP1** & **DIP2** are set to **ON**)

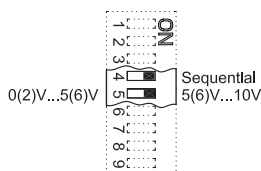

DIP6: Prop./3-pnt - Modulating or 3-point mode selector:

Actuator can operate in modulating (DIP 6 to OFF) or in "simple" 3-point mode, if the 3-point function is selected (DIP 6 to ON).

Modulating mode; DIP 6 set to OFF (factory setting)

- After the actuator has been connected to power supply, the actuator will start the self-adjustment procedure. The indicator LED flashes until self-adjustment is finished.
- Actuator's stem will run to its totally extended or retracted position by bridging SN signal to terminals 1 or 3 and will remain in this position as long as potential is present.
It is not allowed to bridge SP to terminal 1 or 3 when DIP 6 is set to OFF.

3-point mode; DIP 6 set to On

Look carefully wiring diagrams as wiring is different for controllers with triacs output (ECL) in comparison to controllers with relay output.

- Connect SN (Neutral) and power supply (24Vac) via controller to terminals 1 or 3.
- Return signal X (depends on DIP 2, 3, 4 & 5) is possible if connected power supply to SP and SN.

DIP7: LOG/LIN - Equal percentage or linear flow through valve selector¹⁾:

- Characteristic of valve is unchanged by factory setting (DIP 7 OFF).

Danfoss valves as VF, VFS and VFM that are suitable to operate with actuator have logarithmic (equal percentage) flow characteristic. By setting switch to LIN flow the characteristic of motorized valve will be affected. Combination of actuator and valve will work together as valve with LINEAR characteristic.

DIP8: 100 % K_{VS}/Reduced K_{VS} - Flow reduction through valve selector¹⁾:

- If set to OFF position, the flow through valve is not reduced. If set to ON position, the flow through valve reduced by half of increment standard K_{VS} values (example: valve with K_{VS} 16 and DIP8 set to ON – maximum flow through the valve is K_{VS} 13 (middle between standard K_{VS} 16 and K_{VS} 10).

¹⁾ **NOTE:** To be used only in combination with valves with equal percentage characteristic

DIP9: Reset:

- Changing this switch position will cause the actuator to go through a self-adjustment procedure.

Wiring



24 Vac only.

Automatic self-adjustment procedure

The actuator will automatically adjust to the stroke of the valve, when power supply is first time connected to the actuator or when the actuator is reset.

The LED indicator flashes until self-adjustment is finished. The duration depends on the spindle travel and will normally last a few minutes.

To restart self-adjustment, change the position of RESET switch (DIP9).

If the supply voltage is switched off or falls below 80% in more than 0.1s, the current valve position will be stored in the memory also after a power supply cut-out.

Signal on terminals 1 or 3 have priority toward Y input signal.

Diagnostic LED

The red diagnostic LED is located on the pcb under the cover. It provides indication of following operational states:

Constant light

- normal operation

No light

- no operation or no power supply

Intermittent light (1 Hz)

- self-adjusting-mode

Intermittent light (3 Hz):

- power supply too low

- insufficient valve stroke (<20 s)

- end-position cannot be reached.

DIP 6 = OFF
Wiring for modulating mode

SN	0 V	Neutral
SP	24 Vac	Power supply
Y	0(2)-10 Vdc 0(4)-20 mA	Input
1		Input
3		
X	0(2)-10 Vdc	Output

DIP 6 = ON
Wiring for 3-point floating mode
Controller with **relay** output

Actuator needs to perform self-adjustment prior changing DIP 6 to ON.
Output signal depends on DIP 2, 3&5 setting.

SN	0 V	Neutral
SP	24 Vac	Power supply
1		Input
3		
X	0(2)-10 Vdc	Output

DIP 6 = ON
Wiring for 3-point floating mode
Controller with **triacs** output ECL

Actuator needs to perform self-adjustment prior changing DIP 6 to ON.
Output signal depends on DIP 2, 3&5 setting.

SN	0 V	Neutral
SP	24 Vac	Power supply
1		Input
3		
X	0(2)-10 Vdc	Output

Commissioning

Complete the mechanical and electrical installation and perform the necessary checks and tests:

- Isolate control medium. (e.g. self-adjustment in a steam application without suitable mechanical isolation could cause a hazard).
- Apply the power. Note that the actuator will now perform the self-adjustment procedure.
- Apply the appropriate control signal and check the valve stem direction is correct for the application.
- Ensure that the actuator drives the valve over its full stroke, by applying the appropriate control signal. This action will set the valve stroke length.

The unit is now fully commissioned.

Commissioning / testing feature

The actuator can be driven to the fully open or closed positions (depending on valve type) by connecting SN to terminals 1 or 3.

Manual override

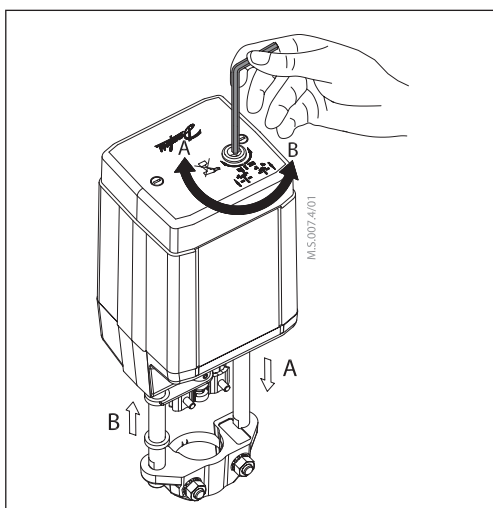
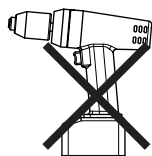

The manual override is applied by rotating the 4 mm Allen key (not supplied) to the required position. Observe the direction of the rotation symbol.

- Disconnect power supply
- Adjust valve position using an Allen key
- Set valve to closed position
- Restore power supply

If manual override has been used then X and Y signal are not correct until the actuator reaches its end position. If this is not accepted reset the actuator, or apply accessory active return signal kit.

Usage of electrical drill machine is not allowed.

Dimensions

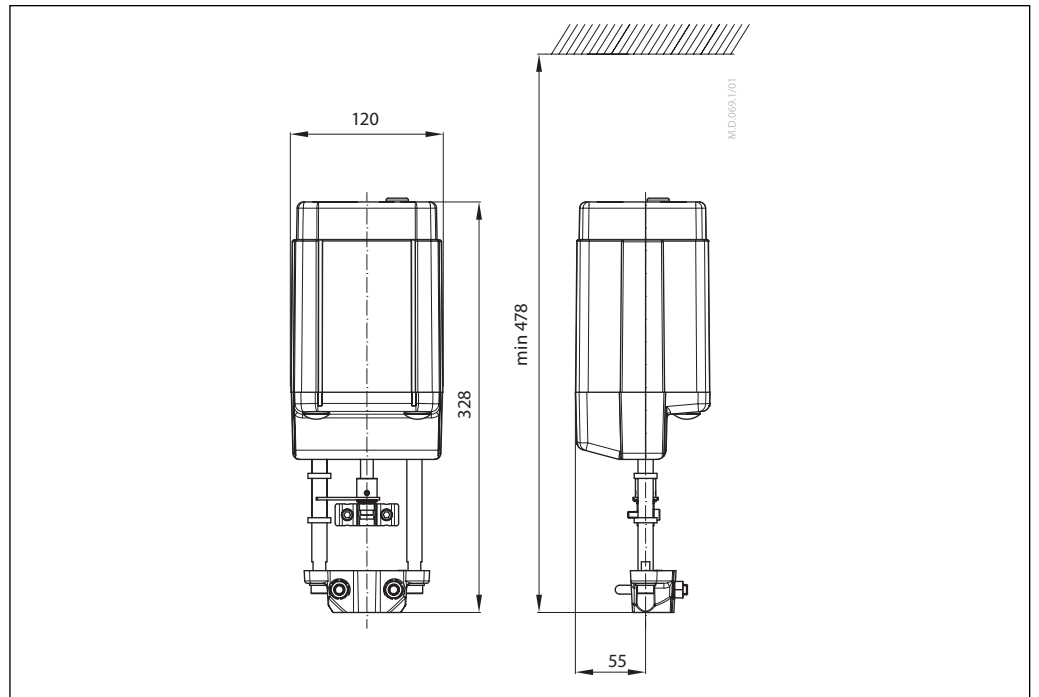

Actuator - valve combinations

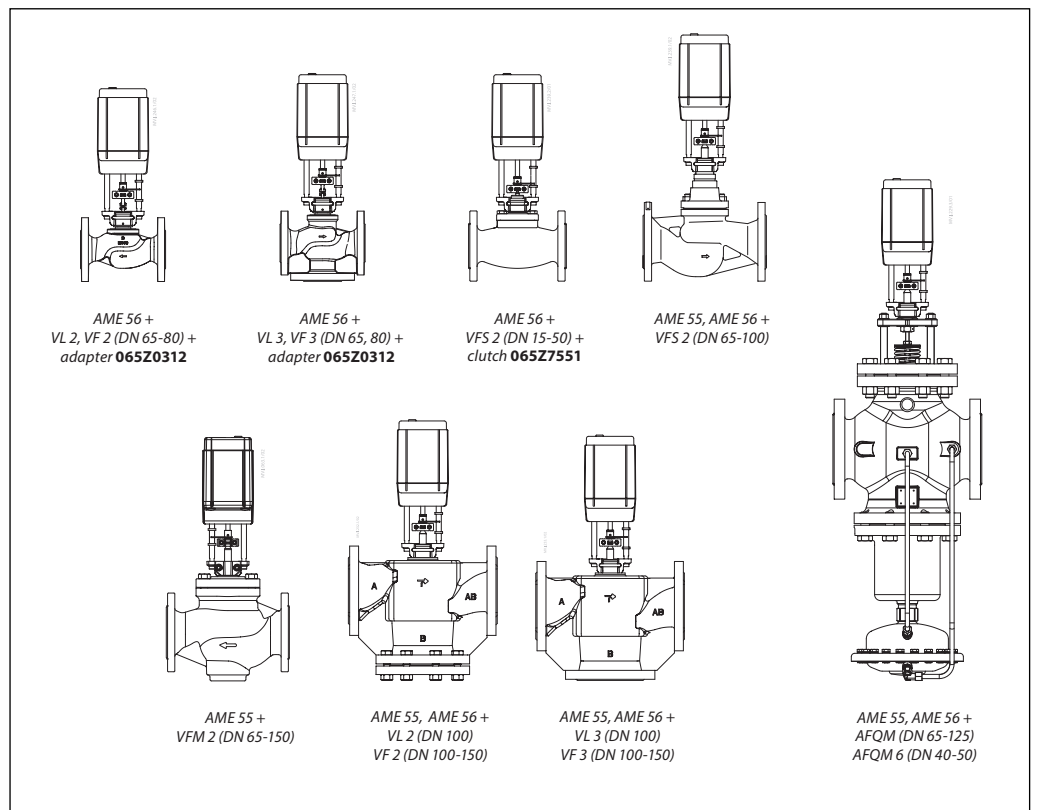



Danfoss A/S

Heating Segment • heating.danfoss.com • +45 7488 2222 • E-Mail: heating@danfoss.com

Danfoss can accept no responsibility for possible errors in catalogues, brochures and other printed material. Danfoss reserves the right to alter its products without notice. This also applies to products already on order provided that such alterations can be made without subsequential changes being necessary in specifications already agreed. All trademarks in this material are property of the respective companies. Danfoss and all Danfoss logotypes are trademarks of Danfoss A/S. All rights reserved.